

Hologram recording by means of fly's-eye lens

E. JAGOSZEWSKI

Institute of Physics, Wrocław University of Technology, Wybrzeże Wyspiańskiego 27, 50-370 Wrocław, Poland.

A method for recording a hologram of three dimensional object illuminated in white light by using fly's-eye lens is presented. First an integral photograph of the object is taken which contains all information in good approximation. By using the coherent light this photographic record is projected through the same fly's-eye lens for yielding an orthoscopic real image the wavefronts of which are recorded forming a hologram.

1. Introduction

The tremendous development of the holographic methods has relegated the traditional optical methods of three-dimensional imaging into the background. The most important method for recording and displaying three-dimensional information was the integral photography proposed in 1908 by LIPPMANN [1], in which the fly's-eye lenses were used. Integral imaging is a powerful tool for recording information, whereas the spatial integrity can be retained in a significant way. The image produced during reconstruction from an integral photograph is pseudoscopic, *i.e.*, the depth of the image is inverted. By recording a second integral photograph the inversion to an orthoscopic image can be done. In this paper, a method for recording holograms of three-dimensional objects that are illuminated with white light is described. Using the fly's-eye lens, an integral photograph is recorded behind its focal plane. If the integral photograph inserted in its original position with regard to the lens is projected through the same lenslets, then it yields a pseudoscopic image, *i.e.*, a real three-dimensional image with inverted depth of the object. Therefore, in the method described the second inversion is done by reflecting the object (or image) wavefronts from the autocollimating screen, whereas this inversion can take place either before or after the recording of the integral photograph.

2. Integral photography

The integral photography is a method of recording three-dimensional images on a photograph plate, while reconstruction from an integral photograph has inverted depth, we say that it is pseudoscopic. The inversion to an image with true depth is usually performed on the pseudoscopic reconstruction by recording a second integral

photograph. In integral photography a fly's-eye lens sheet is used, *i.e.*, an array of spherical lenslets that is inserted in front of the photographic plate. The thickness of the lenslets should be chosen so that the focus of a parallel incident beam is formed on the emulsion. The first method for integral photography design was described by BURCKHARDT [2], who presented, on the one hand, the optimum design theory and, on the other, the resolution limitation. But in the 1960s the technique of lenticular sheet for three-dimensional imaging made great progress. The lenticular sheet is much easier to produce than a fly's-eye lens sheet in integral photography, therefore the lenticular sheet pictures are often seen in everyday life. The lenticular sheet three-dimensional picture is a particular case of the integral photography, in which also the basic principle of recording is to collect spatial image information of the object observed from various directions. In Figure 1, we see an arrangement for making the integral photograph. The photographic plate is located approximately in the focal plane (usually behind the focal plane) of the fly's-eye lens consisting of a great number of small spherical lenses produced from glass or plastic. Upon the emulsion of the photographic plate we can record a great number of small pictures of the object observed from various directions. The object distance is much greater than the focal length of the lenslets, and the images of the object are produced by each lenslet. After exposure the photographic plate is processed, returned to the original position, and illuminated from the rear side (from the right in our case). Each image point of the transparency emits then a spherical wavefront which propagates through the lenslets of the fly's-eye lens and is transformed to the converged beam tracing to the original position of its object point. In this way an observer on the left will see during reconstruction an image with inverted depth, *i.e.*, a pseudoscopic image. Therefore, in the earlier integral photography, a second integral photograph of the

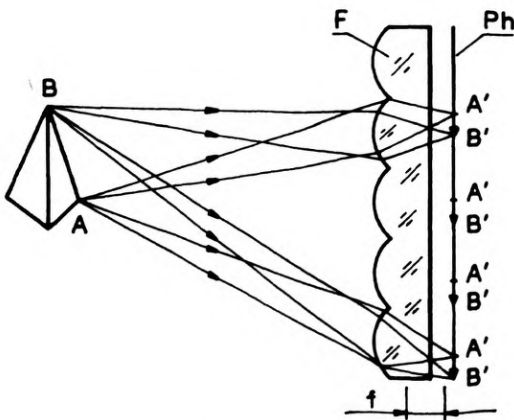

Fig. 1. Recording of a three-dimensional object illuminated in white light. A, B — points of the object, F — fly's-eye lens, Ph — photographic plate, A', B' — images of the object points A, B , respectively, f — focal length of the lenslets

reconstructed image was performed from the left, and after developing was observed from the right as orthoscopic image. Analogously, Burckhardt considered the two-step integral photography [2], where the three-dimensional image reconstructed from the primary photograph is transferred to the secondary photograph as an orthoscopic one. The quality of the three-dimensional images can be defined by measure of the distance between two resolvable spots in the depth direction. Therefore, in the reconstruction process of the image, the rays of light scattered upon spots on the photographic plate will form beams propagating down along the same paths as in taking the photograph, but in opposite direction.

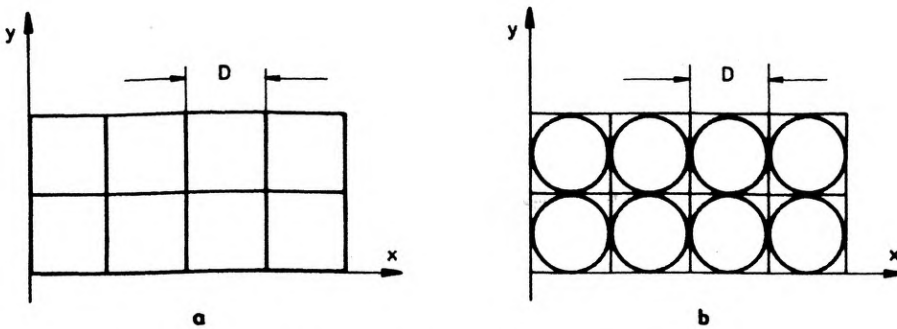

Fig. 2. Fly's-eye lens sheet having square (a) and circular apertures (b). D is a side of the square (or the circular in diameter)

Let us consider a fly's-eye lens sheet having a large number of square lenslets, as shown in Fig. 2a. If a side of the square is equal to D , then diffraction causes the focus to spread on the emulsion, which is described by Fraunhofer diffraction [3], and thus the amplitude distribution in the lateral displacement is given as

$$U(x, y) = A \frac{\sin(vx)}{vx} \frac{\sin(vy)}{vy} \quad (1)$$

where A is constant, and $v = \frac{\pi D}{\lambda f}$. The focal length of the lenslet has to be not smaller than its thickness $t \leq f$. For $t = f$, λ is the wavelength in glass (or plastic) of the lenslet. For improving the quality of the images formed by an integral photograph, a fly's-eye lens with circular lenslets is used (see Fig. 2b). In this case, the amplitude distribution is given by Airy disc [3] and described by Fraunhofer diffraction of a circular aperture

$$U(r) = \frac{2J_1(vr)}{vr} \quad (2)$$

where D is the diameter of the aperture, and v denotes expression as in Eq. (1). In such a lenslets sheet the aberrations from the corners do not exist, since the light

from each corner is removed. Two Equations (2) and (3) express the amplitude distribution obtained as a Fourier transform of the square and circular apertures, respectively, whereas their square determines the intensity distribution in the geometrical image formed in integral photography. Comparing the two Eqs. (1) and (2), we notice that the first zero value of the amplitude distribution is given by

$$\Delta x = \frac{\lambda f}{D} \text{ for a square lens, and} \quad (3)$$

$$\Delta r = 1.22 \frac{\lambda f}{D} \text{ for a circular lens.} \quad (4)$$

We see that the value of Δr is a little greater than the corresponding value of Δx for a square aperture. Following Burckhardt [2], we shall approximate for the square aperture the amplitude distribution on photographic emulsion (in one direction) as Gaussian curve

$$U(x) = A \exp\left(-2.04 \frac{D^2}{\lambda^2 f^2} x^2\right), \quad (5)$$

then the angular spread of light beam will be given as

$$\delta_s = 2 \frac{\lambda}{D},$$

and for the circular aperture

$$\delta_s = 1.22 \cdot 2 \frac{\lambda}{D} = 2.44 \frac{\lambda}{D}.$$

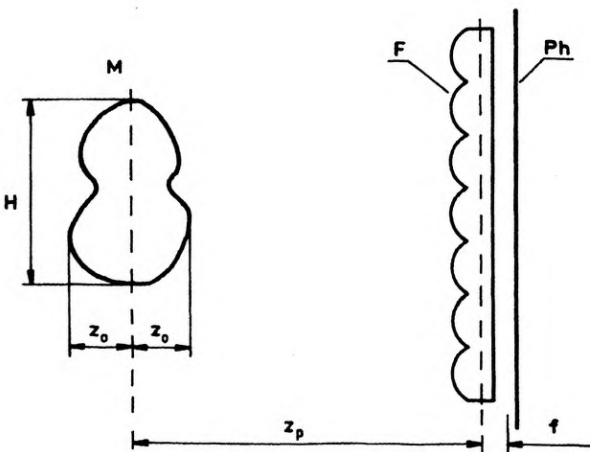

Fig. 3. Arrangement for integral photography. *M* — meridian plane, *Ph* — photographic plate, *H* — object height, $2z_0$ — object depth, z_p — distance between fly's-eye lens and the meridian plane of the object, *f* — focal length (distance between the lenslets and the photographic plate)

Let us consider the arrangement for making an integral photograph of a three-dimensional object shown in Fig. 3. The object of a depth $2z_o$ is located at a distance z_p from the fly's-eye lens sheet and imaged on the emulsion of the photographic plate inserted behind it. In Burckhardt's integral photography the reconstructed image from the primary photograph is then transferred to the second photograph inserted in front of the primary one. In such a scheme, the image is no longer pseudoscopic, but the virtual image is observed behind the secondary photograph as orthoscopic. By minimizing the spread of the Gaussian function, one can obtain an expression for the optimum lens diameter

$$D_{\text{OPT}} = 1.24 z_p \sqrt{\lambda/z_o},$$

and by inserting the following values: $z_p = 50$ cm, $z_o = 5$ cm, $\lambda = 633$ nm, we have for optimum lens diameter $D_{\text{OPT}} = 2.20$ mm. The intensity distribution on the emulsion [2] is then approximately expressed as

$$I(x) = \exp(-4x^2/u^2) \quad (6)$$

where the spread of image is given as

$$u = \sqrt{0.415 \frac{z_o^2 f^2}{z_p^4} D^2 + 0.981 \frac{\lambda^2 f^2}{D^2}}, \quad (7)$$

and for $D = D_{\text{OPT}}$ the minimum resolved angle will be

$$\delta_{\text{min}} = \frac{u}{z_p} = 1.13 \frac{\sqrt{z_o \lambda}}{z_p}.$$

We see that Equation (7) gives us an important conclusion. The first term of u^2 in this equation is proportional to D^2 , while the second one is inversely proportional to the square in diameter ($u^2 \sim D^{-2}$). Indeed, in this way the spread of image depends on the defocusing represented by the first term, and on the diffraction described by the second term.

3. Orthoscopic image and its hologram

Burckhardt's theory contains two-step integral photography, where the primary photograph recorded with arrangement shown in Fig. 1 is reconstructed as a pseudoscopic image. Therefore, the primary photograph is transferred to the secondary photograph by another fly's-eye lens sheet. In such a configuration, the image is no longer pseudoscopic but orthoscopic, and is observed as a virtual image behind the secondary photograph.

This paper describes one-step integral photography in which a hologram of an orthoscopic image is recorded. In this case, first a three-dimensional object is illuminated with white light and imaged by the lenslets of the fly's-eye lens upon the photographic plate. The photograph contains all information of the three-

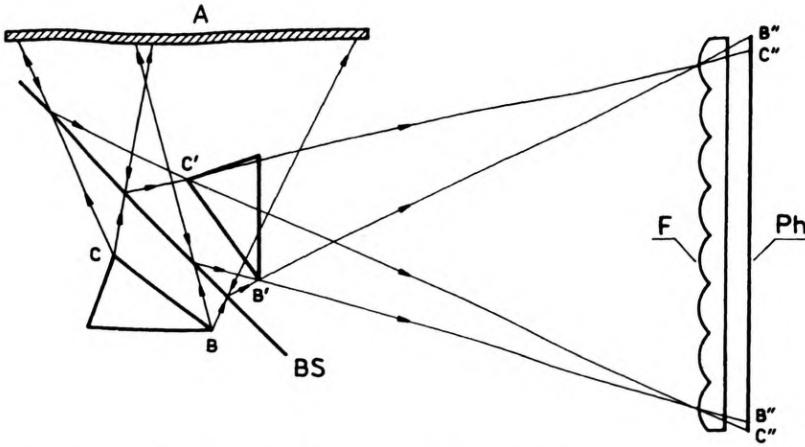

Fig. 4. Recording of an integral photograph by means of autocollimating reflection screen. *A* – autocollimating screen, *F* – fly's-eye lens, *Ph* – photographic plate, *BS* – beam splitter

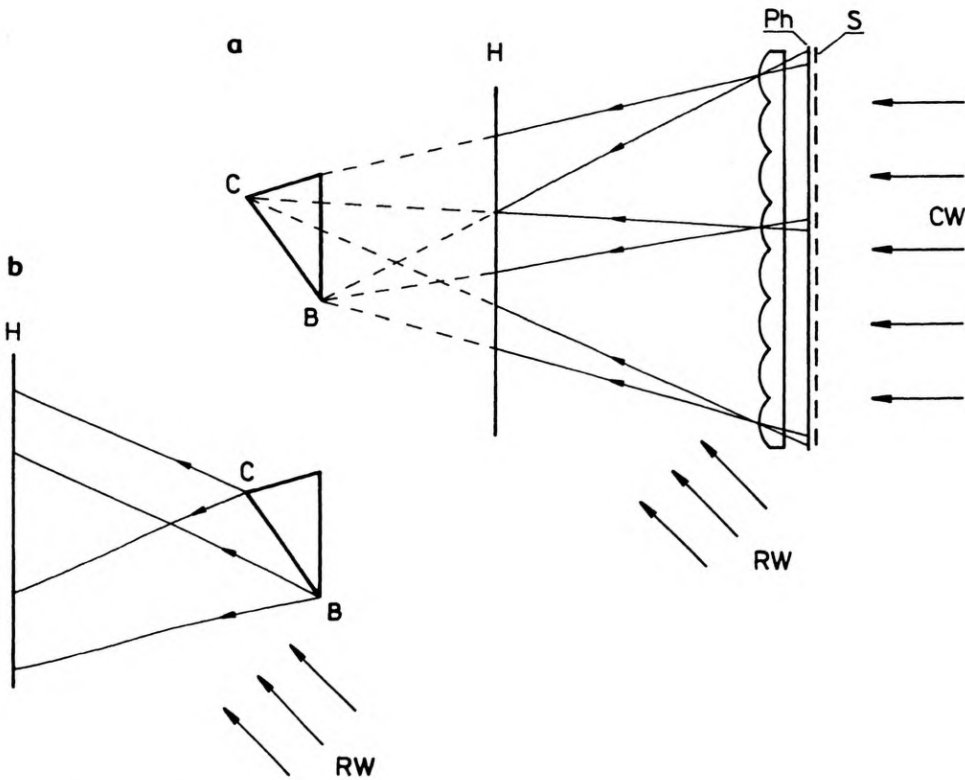

Fig. 5. Hologram recording by means of converging (a) and diverging (b) image wavefronts and a reference plane wavefront. *S* – scatterer, *CW* – coherent illumination plane wave, *RW* – reference plane wave, *H* hologram formed

dimensional scene. The arrangement of recording two points of the object is illustrated in Fig. 4. In this scheme we see first of all the inversion to a pseudoscopic image by the autocollimating screen [4], and the second inversion to an orthoscopic one we obtain by reconstructing the image from the integral photograph. It is well known that the autocollimating screen reflects the incident rays along their incident paths but in the opposite direction. Figure 4 shows the ray-tracing in the optical system of recording arrangement; the light rays emerging from two object points travel to autocollimating screen that reflects every incident ray back onto itself, and then the reflected rays are again reflected from the beam splitter forming the pseudoscopic image on the emulsion of the photographic plate inserted behind the fly's-eye lens sheet. The integral photography stores (a good approximation) of all the information about three-dimensional object in such a manner that it records the orientation of light being scattered from every point on the object with its relative intensity in the emulsion. In this way, the phase information is recorded by means of spatial sampling through the fly's-eye lens as shown in Fig. 1 for two points of the object. Every lens of the lenslets collects a small solid angle from a spherical wavefront emerging from an object point and records it on the emulsion of the photographic plate. In such a way, an array of lenses will record in a discrete manner the wavefront curvatures and their orientations with respect to the photographic plate in terms of relative positions of the sampling points. The resolution of the image points is affected by the aperture of the lenses of the fly's-eye lens, which is chosen as shown by BURCKHARDT [2] and OKOSHI [5] to provide adequate depth of focus.

If the photographic plate is processed and developed as a photographic positive, returned to the original position behind the identical fly's-eye lens and illuminated with the coherent light, then the reverse vision will take place by forming an orthoscopic real image of the object. The light passing through every original point of the image recorded on the photographic plate fills out the aperture of the corresponding lens so that full fractional cones are recreated. For fulfilling this requirement, an additional scatterer could be added as shown in Fig. 5. The scattered light passing through the fly's-eye lens with full information about the amplitude and phase of the object can be recorded on the holographic plate inserted anywhere between the lenslets and the formed real image or behind this image. The two cases are illustrated in Figs. 5a and 5b, respectively. In the first case, when the hologram is illuminated with the plane reference wavefront used for recording, it reconstructs two images of the object; one of them being an orthoscopic real image, while the other is a pseudoscopic virtual one. In the second case, when the hologram is illuminated with the same reference wavefront, it reconstructs a pseudoscopic real image and the orthoscopic virtual image located in the same position as the real image formed by the fly's-eye lens sheet during reconstruction of the photograph.

4. Conclusion

The method described shows how to get a hologram of an object illuminated in white light. We have been concerned with the forming of an orthoscopic three-

dimensional real image the wavefronts of which interfere with the plane wavefront in the holographic emulsion. The hologram can be recorded by means of converging or diverging beams.

References

- [1] LIPPMANN G., *J. Phys.* **7** (1908), 821.
- [2] BURCKHARDT C. B., *J. Opt. Soc. Am.* **58** (1968), 71.
- [3] BORN M., WOLF E., *Principles of Optics*, Pergamon Press Book, New York 1964.
- [4] BURCKHARDT C. B., COLLIER R. J., DOHERTY E. T., *Appl. Opt.* **7** (1968), 627.
- [5] OKOSHI T., *Appl. Opt.* **10** (1971), 2284.

Received April 28, 1998