

Analysis of the luminous flux diffusion on the optical fiber lateral surface

URSZULA BŁASZCZAK, DOMINIK DOROSZ, JAN DOROSZ*,
WŁADYSŁAW DYBCZYŃSKI, MACIEJ ZAJKOWSKI

Białystok Technical University, Wiejska 45D, 15-351 Białystok, Poland

*Corresponding author: doroszjan@pb.edu.pl

The method of the analysis of luminous flux diffusion on the lateral surface of an optical fiber as a basis for designing and manufacturing of side-hole optical fibers is presented. The idea of the controllable emission of the luminous flux by formation of the fiber lateral surface is described. The presented method was verified by manufacturing an optical fiber with controllable emission from the shaped lateral surface.

Keywords: side-hole optical fiber, luminous flux, diffusion, shaped lateral surface.

1. Diffusion of the luminous flux on the lateral surface of optical fiber

The main, widely known, application of an optical fiber is to transfer the optical signal over some distance. In order to achieve this aim, it is necessary, among other things, to reduce energy loss resulting from reflections on the core-cladding border to minimum. In some cases, however, it is recommended to let out the luminous flux through the lateral surface of the optical fiber. The emission of the luminous flux through the lateral surface of the fiber can be realised in many ways [1–4]. One of them assumes the creation of a diffusion layer on the core lateral surface. In this area, some part of the luminous flux from the core penetrates the cladding and then leaves the fiber making its lateral surface shine, whereas the remaining part of the luminous flux gets reflected and stays in the core of this fiber (Fig. 1).

The dominant part of the luminous flux reflected back to the core, encompassed by angle $2\alpha_{kr}$ (smaller than the critical one), reaches the border between the core and the cladding again, and almost completely leaves the fiber through its lateral surface, while the luminous flux encompassed by the range of angles from 90° to $(90^\circ - \alpha_{kr})$ spreads in the fiber core in both directions (also backwards).

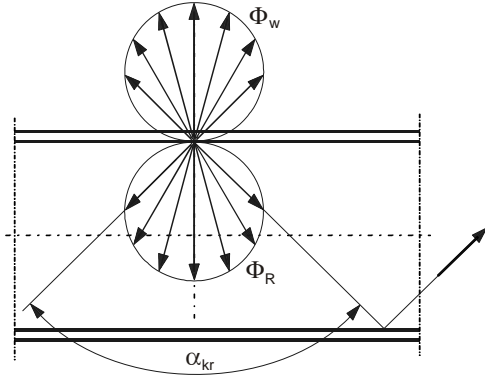

Fig. 1. Local diffusion of the luminous flux on the border between the core and the cladding.

The luminous flux leaving the fiber through its lateral surface depends on the coefficient of transmission τ of the cladding and its coefficient of absorption. The coefficient of reflection ρ , on the other hand, will determine the luminous flux reflected from the elementary diffusion surface and directed back to the core.

The analysis of the division of the elementary flux Φ_p incident on elementary surface can be carried out by making some simplifying assumptions [3].

1. The ray (vector) represents the elementary luminous flux $\Delta\Phi$ encompassed by the elementary solid angle $\Delta\omega$.
2. The optical fiber (with a step-index profile) is rectilinear and its parameters are known: r – radius of the core, n_1 – refractive index of the core, n_2 – refractive index of the cladding.
3. The diffusion layer is flat.
4. The elementary surface is characterised by perfect diffusion, both as far as transmission and reflection are concerned.
5. The values of transmission and reflection coefficients of the elementary surface are known.
6. The value of the luminous flux Φ_p is known.

The luminous flux Φ_w leaving the fiber can be determined from the relation:

$$\Phi_w = \Phi_p \quad (1)$$

while the luminous flux Φ_r directed again into the fiber core

$$\Phi_r = \rho \Phi_p \quad (2)$$

becomes divided into part Φ_b leaving the fiber on the side opposite to the elementary surface (within the area of angle $2\alpha_{kr}$) and part Φ_d , propagated in the core.

$$\Phi_r = \Phi_b + \Phi_d \quad (3)$$

In order to determine the values of the luminous fluxes Φ_b and Φ_d , the half-space adjacent to the elementary surface ΔS should be divided into elementary solid angles

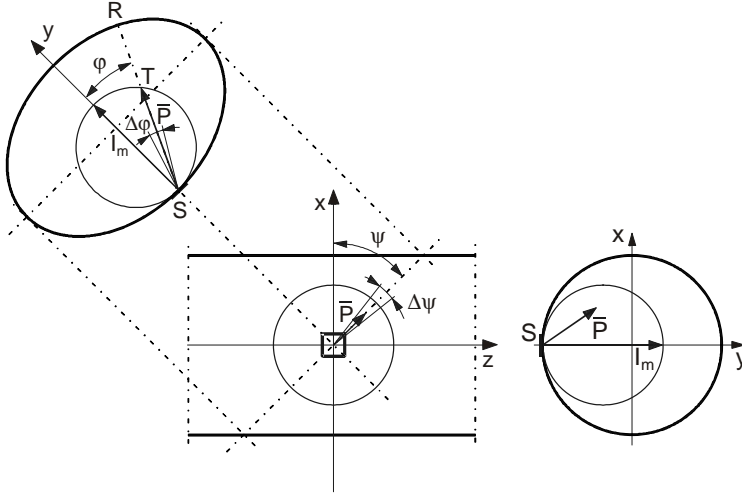

Fig. 2. Polar coordinate system connected with the solid of light distribution.

(Fig. 2). For this purpose, a polar coordinate system is adapted with the central point of the system located in the middle of the discussed elementary area ΔS . This space is divided by planes crossing the y -axis of the Cartesian coordinate system within the distance of angles $\Delta\psi$ starting from the planes x, y . In each plane ψ a division of the space into elementary angles $\Delta\varphi$ is assumed. In chosen plane ψ , the vector \mathbf{P} and the axis y create an angle φ . The length of vector \mathbf{P} directed to point T on the surface of the solid of light distribution equals [3]

$$|\mathbf{P}| = I_m \cos \varphi \tag{4}$$

while

$$I_m = \frac{\Phi_r}{\pi} \tag{5}$$

The assumed polar coordinate system enables us to dividing the solid of light distribution of the reflected flux into bands (variable angle φ with $\psi = \text{const}$) and into zones (variable angle ψ with $\varphi = \text{const}$). In order to divide the half-space into elementary solid angles with approximate values, different values of elementary angles $\Delta\psi$ were assumed in particular zones with values approximate to $\Delta\varphi = \text{const}$. The number k of elementary angles $\Delta\psi$ in a given zone was calculated from the following relation [3]:

$$k = INT \left(\frac{2\pi \sin \varphi}{\Delta\varphi} + 1 \right) \tag{6}$$

Thus, the value of the elementary angle $\Delta\psi$ equals $2\pi/k$.

The accuracy of performed numerical calculations was estimated. For this purpose, the determined luminous fluxes for each elementary angle were summed and compared with the flux Φ_r . The value of the relative error δ was determined from the relation:

$$\delta = \frac{\sum \Delta \Phi - \Phi_r}{\Phi_r} \quad (7)$$

where: δ – relative error, Φ_r – reflected luminous flux (theoretical value), $\sum \Delta \Phi$ – sum of all luminous fluxes encompassed in the elementary angles $\Delta \varphi$ and $\Delta \psi$.

The number m of the elements of angle φ ranged from 8 to 90. The results concerning error estimation are presented in Fig. 3. Dividing angle φ every 1° and angle ψ according to relation (6), 20672 elementary solid angles are obtained in total. Error δ (relation (7)) does not exceed 0.00127%.

Knowing the direction and the sense of vector \mathbf{P}_i (Fig. 2), which defines the value of the elementary luminous flux $\Delta \Phi$, encompassed by the elementary solid angle $\delta \omega_i$, it is possible to determine the point R being the intersection of the line overlapping vector \mathbf{P}_i with the core-cladding border.

The components of vector \mathbf{P}_i are:

$$\left. \begin{aligned} P_x &= \mathbf{P} \sin \varphi \cos \psi \\ P_y &= \mathbf{P} \cos \varphi \\ P_z &= \mathbf{P} \sin \varphi \sin \psi \end{aligned} \right\} \quad (8)$$

These components are proportional to vector \mathbf{RS} directed to the aforementioned point R :

$$\left. \begin{aligned} \frac{x_R - x_S}{z_R - z_S} &= \frac{P_x}{P_z} \\ \frac{y_R - y_S}{z_R - z_S} &= \frac{P_y}{P_z} \end{aligned} \right\} \quad (9)$$

It is also known that point R is located on the core-cladding border, thus it satisfies the following equation:

$$x_R^2 + y_R^2 = r^2 \quad (10)$$

Solving the system of equations (9) and (10), the location of point R can be found. Vector \mathbf{N}_R normal to the outer surface of the core has its components $\mathbf{N}_R (-x_R, -y_R, 0)$ in point R .

As the results of above calculations are known, the angle of incidence α of the luminous flux on the core surface can be determined [3]:

$$a_i = \arccos(\mathbf{P}_i, -\mathbf{N}_R) \quad (11)$$

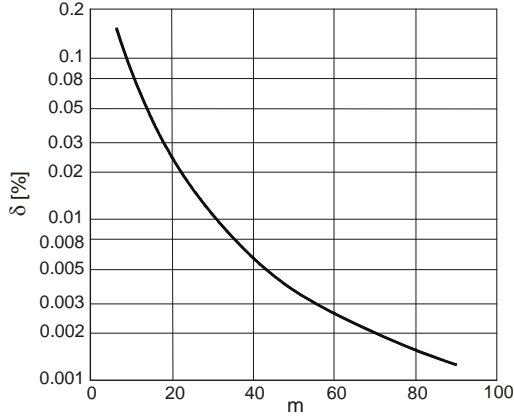

Fig. 3. Value of error δ versus number m of elementary angles φ .

If angle α_i is larger than a certain critical value α_{kr} , the phenomenon of total internal reflection occurs and this elementary luminous flux is joined and propagated in the fiber core Φ_d . Angle α_{kr} depends on the refractivity of the core and cladding:

$$\alpha_{kr} = \arcsin \frac{n_2}{n_1} \quad (12)$$

If the angle of incidence α_i of the elementary luminous flux is smaller than the critical value α_{kr} , the phenomenon of Fresnel reflection takes place and only a small part of the flux is reflected (ρ_f), while its substantial part goes to the cladding. The Fresnel reflection coefficient can be determined from the relation:

$$\rho_f = \frac{1}{2} \left[\frac{\sin^2(\alpha_i - \beta_i)}{\sin^2(\alpha_i + \beta_i)} + \frac{\tan^2(\alpha_i - \beta_i)}{\tan^2(\alpha_i + \beta_i)} \right] \quad (13)$$

where $\beta_i = \arcsin\left(\frac{n_1}{n_2} \sin \alpha_i\right)$ is the angle of refraction.

The luminous flux, which goes to the cladding, is added to the sum Φ_b , because it leaves the fiber through the lateral surface.

A part of the luminous flux reflected from the core lateral surface is proportional to the reflection coefficient ρ_f . It reaches the core lateral surface which is again opposite to the point S . The angle of incidence is also equal to α_i , thus its dominant part goes to the cladding, though the phenomenon of Fresnel reflection appears here as well. This phenomenon occurs many times and the luminous flux is constantly weakened.

Adding up the elementary luminous fluxes Φ_d and Φ_b , their percentage participation in Φ_r can be determined depending on the known parameters. The calculation results are shown in Fig. 4. The following data were assumed for these calculations: transmission coefficient of the cladding $\tau = 0.5$; reflection coefficient of the cladding $\rho = 0.5$; refractive index of the cladding was changed to provide the numerical aperture varying in a wide range.

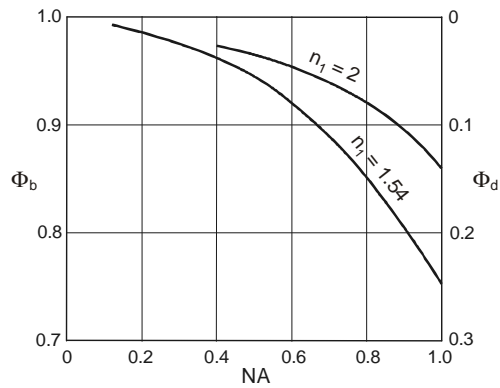

Fig. 4. Luminous flux Φ_b coming out of the fiber through its lateral surface and Φ_d running on in the core (relative values) in the function of numerical aperture NA.

The analysis presented above proves that irrespectively of the direction of the ray incidence on the cladding surface, the luminous flux in the core is propagating along the fiber in both directions.

2. Diffusion of the luminous flux as a result of formation of the fiber lateral surface

Emission of light through the fiber lateral surface can be obtained through appropriate formation of its cladding. It seems that the easiest way is to make notches on the fiber lateral surface whose active surfaces are covered with a diffusing layer with the same refractive index as a cladding (Fig. 5).

It is assumed that the active surface of the notch is divided into elementary surfaces. On each elementary surface the luminous flux diffuses in both directions outside the fiber and inside the core. Besides, the following simplifying assumptions are made:

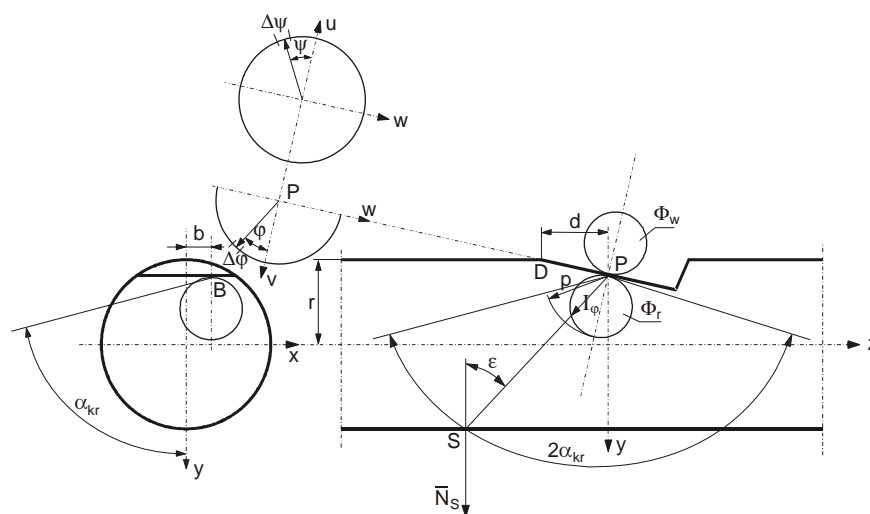

Fig. 5. Division of the elementary luminous flux on the notch active surface.

1. The ray of light represented by a vector is a carrier of the elementary luminous flux $\Delta\Phi$ encompassed by the elementary solid angle $\Delta\omega$.

2. The following parameters of the optical fiber are known (Fig. 5): γ – angle of inclination of the notch, r – radius of the core, d – distance from the analysed point to the beginning of the notch (along the z -axis), b – distance from the analysed point to the axis of symmetry (along the x -axis); the cladding thickness is insignificantly small.

3. The elementary surface of the notch is characterised by even diffusion, both during transmission and reflection of the luminous flux.

4. Values of the following coefficients are known: transmission τ and reflection ρ of the notch active surface.

The luminous flux Φ_p incidents the elementary surface, in the middle of which the analysed point is located (Fig. 5), and becomes divided into three parts: Φ_r – part of the luminous flux directed back to the core, Φ_w – the luminous flux going outside and Φ_α – the flux absorbed by the diffusing layer:

$$\Phi_p = \Phi_r + \Phi_w + \Phi_\alpha = \rho\Phi_p + \tau\Phi_p + \alpha_p\Phi_p \quad (14)$$

where α_p – absorption coefficient of the cladding.

The luminous flux directed back into the core Φ_r in its considerable part (Φ_b) leaves the fiber through the surface at the place located opposite the notch. When the angle of the luminous beam incidence, however, is larger than the critical angle, the phenomenon of total internal reflection occurs. Then, this small part of the luminous flux propagates along the fiber in both directions. The luminous flux running in accordance with the direction of propagation (the z -axis) is marked Φ_d , and the one running in the opposite direction – Φ_u .

Thus, the reflected luminous flux Φ_r gets divided into three parts

$$\Phi_r = \Phi_b + \Phi_d + \Phi_u \quad (15)$$

In order to determine the percentage participation of the flux in each part, a polar system of coordinates p, φ, ψ is adapted with its centre located in the analysed point P . This point is situated on the notch active surface. In the Cartesian system its coordinates are $(b, r - a, 0)$. The polar coordinate system is rotated at angle γ around the axis parallel to the x -axis and crossing it in point P . Angle φ is measured from the v -axis, perpendicular to the notch active surface, whereas angle ψ is located in the plane of the notch surface.

A randomly chosen point T , located within the distance p from point P , is described by the following coordinates [3, 5]:

$$\left. \begin{aligned} v_T &= p \cos \varphi \\ u_T &= p \sin \varphi \cos \psi \\ w_T &= p \sin \varphi \sin \psi \end{aligned} \right\} \quad (16)$$

In the Cartesian coordinate system x, y, z this point is described by the relations:

$$\left. \begin{aligned} x_T &= p \cos \varphi \cos \psi + b \\ y_T &= p \cos \varphi \cos \gamma + p \sin \varphi \sin \psi \sin \gamma - r + a \\ z_T &= p \sin \varphi \sin \psi \cos \gamma - p \cos \varphi \sin \gamma \end{aligned} \right\} \quad (17)$$

Determination of the angle of incidence ε of the ray overlapping the direction of light intensity $I_{\varphi, \psi}$ on the core lateral surface is a significant part of the analysis. The light intensity and the value of the elementary solid angle $\Delta\omega_{\varphi\psi}$ are a measure of the elementary luminous flux. By comparing the angle of incidence ε with the value of the critical angle, the considered luminous flux can be rated to a proper part of the flux, according to relation 15. When angle ε is larger than the critical one, then the location of point S on the core surface determines the further division of this flux. Thus, if $z_S < 0$, the elementary luminous flux propagates in the opposite direction (Φ_u), and when $z_S > 0$, it runs according to the direction of propagation (Φ_d).

In the calculations, the even division of angle φ into m -element zones is assumed, whereas angle ψ is divided equally in each zone to obtain approximately equal elementary solid angles $\Delta\omega_{\varphi\psi}$. Thus, the number n of elementary angles ψ for each zone is determined from the relation:

$$n_i = INT \left(\frac{2\pi \sin \varphi}{\Delta\varphi} + 1 \right) \quad (18)$$

where: $\Delta\psi = 90^\circ/m$, i – number of the zone.

Point S , located at the intersection of the straight line going through points P and T with the core side surface, can be determined from the following system of equations:

$$\left. \begin{aligned} \frac{x - x_P}{x_T - x_P} &= \frac{y - y_P}{y_T - y_P} = \frac{z - z_P}{z_T - z_P} \quad \text{equation of the line} \\ x^2 + y^2 &= r^2 \quad \text{equation of the cylindrical surface} \end{aligned} \right\} \quad (19)$$

The solution of this system of equations, after applying the substitution method, is the quadratic equation (7) in the form:

$$\begin{aligned} &\left[\frac{(x_T - b)^2}{y_T + r - a} + 1 \right] y_S^2 + 2 \left[\frac{(x_T - b)^2 (r - a)}{(y_T + r - a)^2} + \frac{b(x_T - b)}{y_T + r - a} \right] y_S + \\ &+ \frac{(x_T - b)^2 (r - a)^2}{(y_T + r - a)^2} + 2 \frac{b(x_T - b)(r - a)}{y_T + r - a} + b^2 - r^2 = 0 \end{aligned} \quad (20)$$

Getting the coordinate y_S of point S from the system of equations (19), the coordinates x_S and z_S can be determined.

The normal unit vector has its components $\mathbf{N}_S(x_S/r, y_S/r, 0)$ in point S , thus angle ε can be calculated from the relation:

$$\cos \varepsilon = \cos \left(\frac{\mathbf{N}_S \cdot \mathbf{SP}}{|\mathbf{SP}|} \right) \quad (21)$$

whereas vector \mathbf{SP} has the components:

$$\mathbf{SP}(x_S - x_P; y_S - y_P; z_S - z_P) = \mathbf{SP}(x_S - b; y_S + r - a; z_S)$$

If the following inequality is satisfied

$$\frac{n_1}{n_2} \sin \varepsilon < 1 \quad (22)$$

where: n_1 – refractive index of the core material, n_2 – refractive index of the cladding material; the elementary luminous flux runs from the core to the cladding. In this case angle ε is smaller than the critical one. The luminous flux formed due to Fresnel phenomenon incidents the lateral surface of the core again at the same angle ε and its dominant part goes to the cladding as well. Therefore, this phenomenon was not analysed as it influences only the direction of the outlet of the luminous flux and has no impact on its value.

If the following inequality is satisfied

$$\frac{n_1}{n_2} \sin \varepsilon > 1 \quad (23)$$

the phenomenon of total internal reflection occurs on the border between the core and the cladding and the luminous flux becomes divided and propagates along the core in both directions. This division does not have to be equal.

The following values are assumed for the calculations:

- number of zones in angle φ is $m = 91$,
- number of elements of angle ψ is $n = 4-360$,
- radius of the core r equal to 5 arbitrary units,
- angle of the notch inclination $\gamma = 0^\circ-40^\circ$,
- distance from the discussed point to the beginning of the notch $d = 0-10$ units,
- distance from the discussed point to the axis of symmetry $b = 0-4.5$ units,
- refractive index of the core $n_1 = 1.54$,
- refractive index of the cladding $n_2 = 1.399-1.530$,
- numerical aperture of the fiber is selected in order to get the following acceptance angles $\alpha = 10^\circ, 20^\circ, 30^\circ$ and 40° .

Figure 6 presents the calculated percentage value of the luminous flux Φ_b , leaving the fiber through the lateral surface in relation to the flux Φ_r , reflected from the core-cladding border versus the angle γ of the notch inclination for chosen values of the acceptance angle α .

Figure 7 presents the courses of relative values of the luminous fluxes Φ_d and Φ_u (in relation to the flux Φ_r) propagating in the core: according to the sense of the z -axis

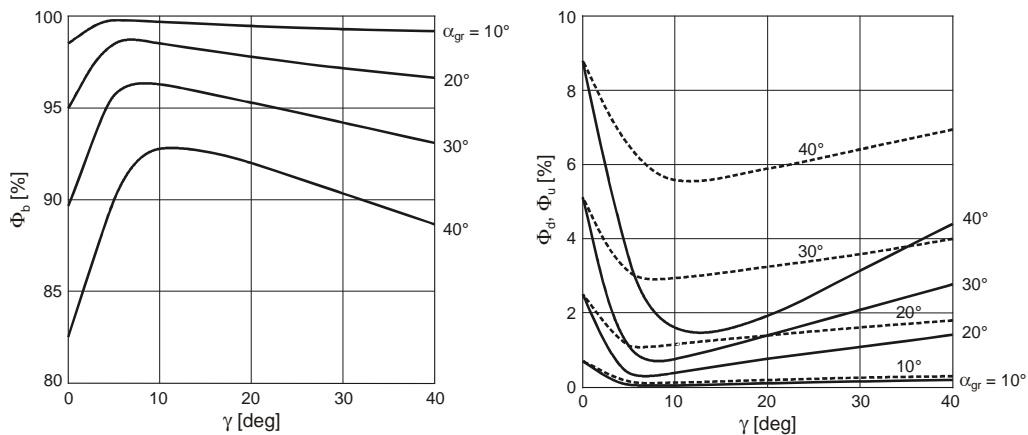

▲
Fig. 6. Relative value of the luminous flux Φ_b leaving the fiber through its lateral surface versus the angle γ of the notch inclination.

Fig. 7. Relative values of the luminous fluxes Φ_d and Φ_u in the function of angle γ of the notch inclination: Φ_d – continuous lines; Φ_u – dashed lines.

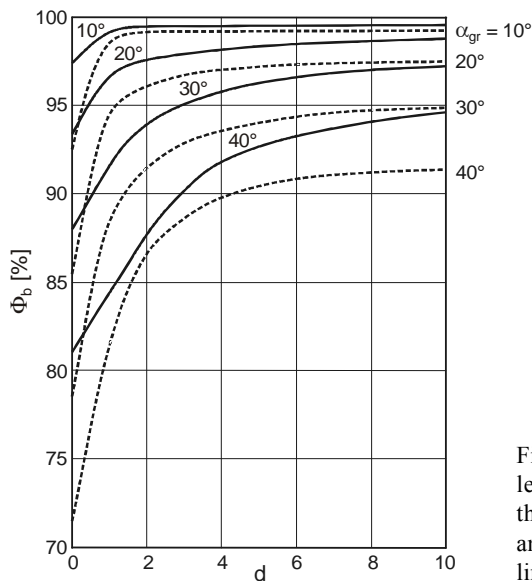
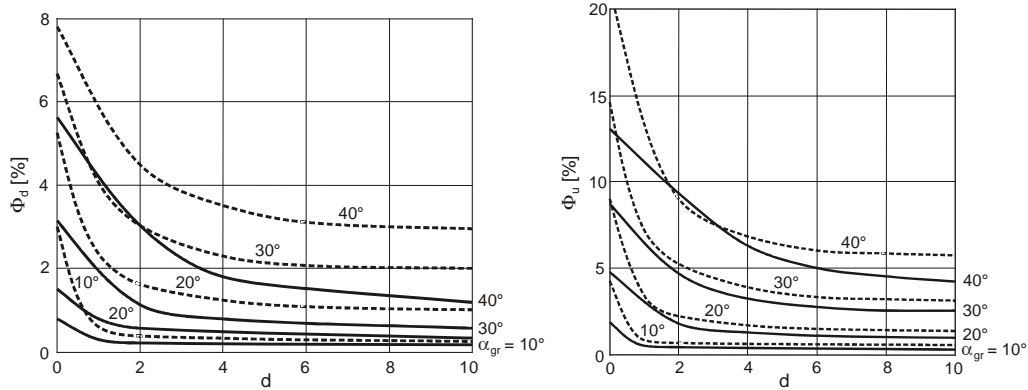

Fig. 8. Relative value of the luminous flux Φ_b leaving the fiber through the lateral surface versus the distance d for four values of the acceptance angle α : $\gamma = 10^\circ$ – continuous lines; $\gamma = 30^\circ$ – dashed lines.

and in the opposite direction, respectively, versus the angle γ of the notch inclination for four values of the fiber acceptance angle.

The values of the luminous fluxes (Φ_b , Φ_d and Φ_u) depend on the position of the analysed point P on the notch active surface as well. The course of changes in the relative value of the luminous flux Φ_b leaving the fiber through its lateral surface versus the distance d between the position of the analysed point and the point P along



▲ Fig. 9. Relative value of the luminous flux Φ_d propagating in the fiber core in the direction compatible with the sense of the z -axis versus the distance d for four values of the fiber acceptance angle α : $\gamma = 10^\circ$ – continuous lines; $\gamma = 30^\circ$ – dashed lines.

Fig. 10. Relative value of the luminous flux Φ_u propagating in the fiber core in the direction opposite to the sense of the z -axis versus the distance d for four values of the fiber acceptance angle α : $\gamma = 10^\circ$ – continuous lines; $\gamma = 30^\circ$ – dashed lines.

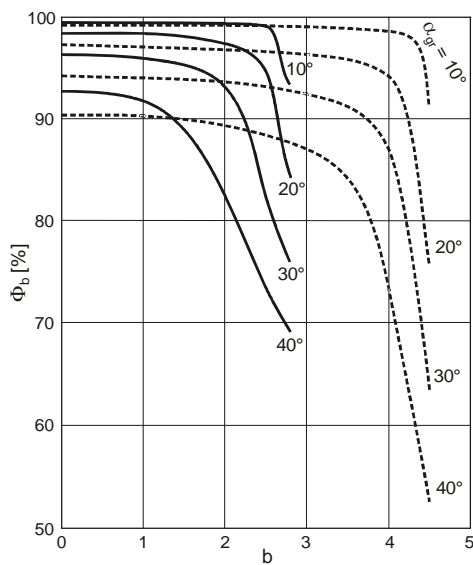
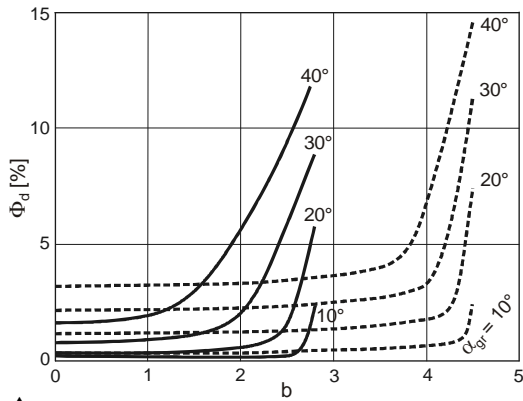

Fig. 11. Relative values of the luminous flux Φ_b leaving the fiber through the lateral surface versus the distance b from the position of the analysed point P for four values of the fiber acceptance angle α : $\gamma = 10^\circ$ – continuous lines; $\gamma = 30^\circ$ – dashed lines.

the z -axis (point D in Fig. 5), for four values of the fiber acceptance angle α and two values of angle γ of the notch inclination is presented in Fig. 8. Figures 9 and 10 show the courses of relative values of the luminous fluxes (Φ_d and Φ_u) versus the distance d for four values of angle α and two values of angle γ .

The influence of the position of point P in the transverse direction (along the x -axis) on the values of the analysed luminous fluxes was examined. The course of the changes (in relative values) of the luminous flux Φ_b leaving the fiber through the lateral surface versus the distance b determines the position of the analysed point to the axis of symmetry towards the x -axis (point B in Fig. 5), for four values of the fiber acceptance angle α and two values of angle γ of the notch inclination is presented in Fig. 11.

Figures 12 and 13 show the relative values of the luminous fluxes Φ_d and Φ_u propagating in the core in direction compatible with the sense of the z -axis and in the opposite direction, respectively.



▲ Fig. 12. Relative values of the luminous flux Φ_d propagating in the fiber core in the direction compatible with the sense of the z -axis in the function of distance b for four values of the fiber acceptance angle α : $\gamma = 10^\circ$ – continuous lines; $\gamma = 30^\circ$ – dashed lines.

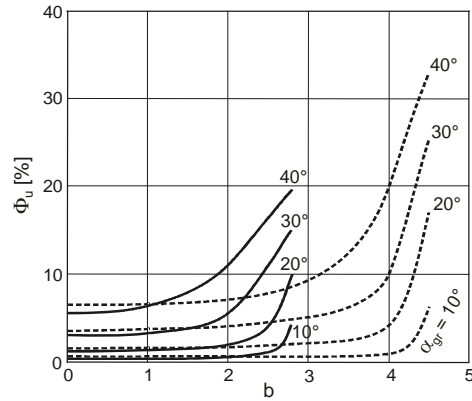

Fig. 13. Relative values of the luminous flux Φ_u propagating in the fiber core in the direction opposite to the sense of the z -axis in the function of distance b for four values of the fiber acceptance angle α : $\gamma = 10^\circ$ – continuous lines; $\gamma = 30^\circ$ – dashed lines.

On the basis of the above analysis the lateral optical fiber was manufactured (Fig. 14a) [5]. The luminance distribution of this fiber was measured and the results are presented in Fig. 14b.

3. Conclusions

On the basis of the analysis of presented results, we can conclude the following:

1. With the increase in the fiber acceptance angle α , the luminous flux Φ_b leaving the fiber through the lateral surface decreases, while the luminous fluxes Φ_d and Φ_u

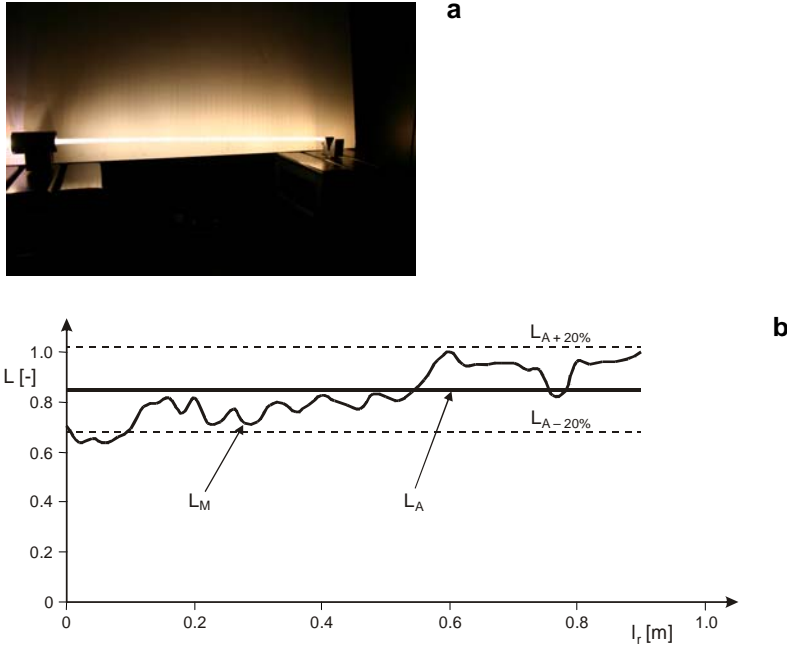

Fig. 14. Optical fibers with controllable lateral surface (a); luminance distribution of the manufactured optical fiber: L_A – Average luminance, L_M – measured luminance (b).

running along the fiber core increase in value: relative to the sense of the z -axis and in the opposite direction, respectively.

2. With the increase in the inclination angle of the notch active surface γ , the luminous flux Φ_b leaving the fiber through the lateral surface increases rapidly at first, and then, after reaching a certain maximum value, decreases slowly. The luminous fluxes Φ_d and Φ_u , however, propagating in the core behave in an opposite way: along with the increase in angle γ they reduce rapidly in order to increase gently afterwards.

3. With the increase in the distance d of the location of analysed point along the z -axis of the optical fiber, the luminous flux Φ_b leaving the core through the lateral surface increases, and the luminous fluxes Φ_d and Φ_u are reduced.

4. With translocation of the analysed point P along the x -axis (dimension b in Fig. 2) the luminous flux Φ_b leaving the fiber through the lateral surface decreases gently, and near the notch lateral edge it is reduced dramatically. The luminous fluxes Φ_d and Φ_u behave in an opposite way, as they increase gently in the dominant part of value b in order to increase rapidly near the notch edge.

5. If the notch geometry and material parameters of the fiber are known, it is possible to determine the percentage division of the luminous flux Φ_r reflected to the core, originated from the active surface of the notch. For example, if $r = 5$, $\alpha = 30^\circ$ and $d_{\max} = 10$, the components of this flux are: $\Phi_b = 0.951 \Phi_r$, $\Phi_d = 0.017 \Phi_r$, $\Phi_u = 0.032 \Phi_r$. In some cases, when the division procedure is introduced, the numerical

analysis is simplified without generating any major errors. This can be useful in the process of designing an optical fiber, which emits radiation through the lateral surface.

Acknowledgments – The work was supported by Polish Ministry of Science and Higher Education, Research Project No. 3T08D 046 29.

References

- [1] PENG LEE, *Shaped optical fiber light and manufacturing method thereof*, United States Patent No.7258476.
- [2] ZAJKOWSKI M., *The analysis of light flux distribution from shaping optical fiber*, Proceedings of SPIE **6347**, 2006.
- [3] DOROSZ J., DYBCZYŃSKI W., *Analysis of luminous flux transfer through a conical ring-core light guide*, *Optica Applicata* **34**(3), 2004, pp. 349–364.
- [4] PUSTELNY T., BARCZAK K., GUT K., WOJCIK J., *Special optical fiber type D applied in optical sensor of electric currents*, *Optica Applicata* **34**(4), 2004, pp. 531–539.
- [5] DOROSZ D., ZAJKOWSKI M., *Optical properties of glasses for sight light emission waveguides*, Proceedings of XXI International Congress on Glass, Strasbourg, France 2007.

Received May 2, 2008