

Quartz enhanced photoacoustic spectroscopy based on an external cavity quantum cascade laser

LINGUANG XU, SHENG ZHOU, TIANBO HE, JINGSONG LI*

Laser spectroscopy and sensing laboratory, Anhui University, 230601 Hefei, China

*Corresponding author: jingsong_li@ahu.edu.cn

Mid-infrared laser spectroscopy is a powerful analytical tool for trace gases detection. In this study, a spectroscopic system based on an external cavity quantum cascade laser (ECQCL) and quartz enhanced photoacoustic spectroscopy (QEPAS) was developed for volatile organic compounds (VOCs) measurements. Primary laboratory test on ethanol spectroscopy was investigated and compared with traditional direct absorption spectroscopy (DAS). Experimental results show that the proposed QEPAS is more sensitive than the conventional DAS method. In addition, the significant linear dependence of photoacoustic signal on sample pressures and laser operating parameters was observed.

Keywords: external cavity quantum cascade laser (ECQCL), quartz enhanced photoacoustic spectroscopy (QEPAS), volatile organic compound (VOC), ethanol.

1. Introduction

The mid-infrared (MIR) region of the electromagnetic spectrum (between 2.5 and 25 μm) is of particular interest for spectroscopy measurements, since many gas molecules have their strong absorption fingerprints in this band. Quantum cascade laser (QCL) as a new type MIR laser has many advantages over traditional laser sources, such as small size, wide wavelength tuning range, compactness, high power and low power consumption [1]. With the fast development of QCL technology [2], QCL based spectroscopy techniques have been widely used for quantitative chemical detection in various fields including atmospheric monitoring, industrial processing control, public safety and biomedical study, *etc.* [3, 4]. The tuning range available from a single QC chip has been achieved over 400 cm^{-1} by employing an external cavity technology [5, 6], *i.e.* external cavity quantum cascade laser (ECQCL), which shows significant advantages on multi-species detection and chemical warfare agent analysis.

Photoacoustic spectroscopy (PAS) is a high-sensitivity, high-resolution spectroscopy based on the photoacoustic effect, which was firstly discovered by BELL in 1880 [7]. In 2002, a new type of PAS technology called quartz enhanced photoacoustic spec-

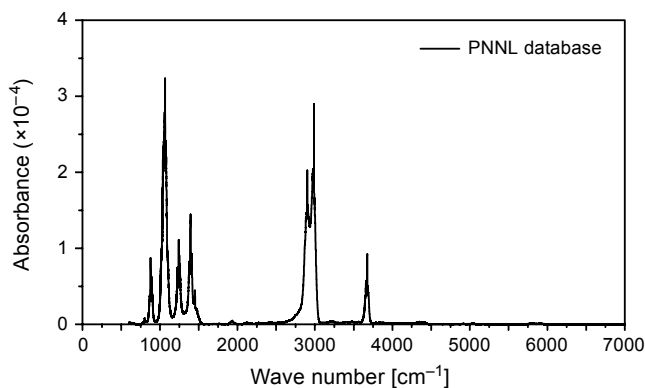

Fig. 1. Ethanol absorption spectrum taken from PNNL database.

trosopy (QEPAS) using a quartz tuning fork (QTF) as an acoustic signal detector [8], was proposed by KOSTEREV *et al.* [9]. Tuning fork quartz crystal oscillator is widely used because of small size, low price, and a good immunity to other noise sources. With rapid development in recent years, QEPAS sensor technology is widely used to detect several molecules with rotational resolution with good resolution in the near infrared spectrum, but also to larger molecules such as ethanol, acetone and Freon [10–12]. Generally, absorption spectra of these complex molecules consist of rather wide bands. Each band includes many absorption lines located very close to each other, which are not resolved even at low pressure due to Doppler's effect. For instance, Fig. 1 presents ethanol absorption spectrum, which is based on the PNNL database of atmospheric pressure FTIR spectra [13]. As can be seen from this figure, the absorption spectrum of ethanol includes much stronger bands with different peculiarities in the mid- and far-infrared range, which are ideal bands for detection and identification of ethanol vapor, comparing to the near-infrared range [14].

In this study, a spectroscopic system based on a broadband ECQCL and QEPAS technique was developed for volatile organic compounds (VOCs) measurements. Primary laboratory test on ethanol PA spectroscopy measurement was investigated and compared with traditional direct absorption spectroscopy (DAS). Moreover, the dependence of PA signal on sample pressures and laser operating parameters was also discussed in details.

2. Experimental details

The experimental setup is shown in Fig. 2. The system mainly consists of a broadband tunable ECQCL (Marlborough, MA, USA) provided by Block Engineering, a diaphragm plate, a collimator lens (CaF_2 , diameter 36 mm, focal length $f = 60$ mm), a home-made cylindrical PA cell with a volume of ~ 100 ml, a mercury cadmium telluride (MCT) detector (PVMI-4TE-10.6, Vigo Systems) and a data acquisition card (NI USB-6259,

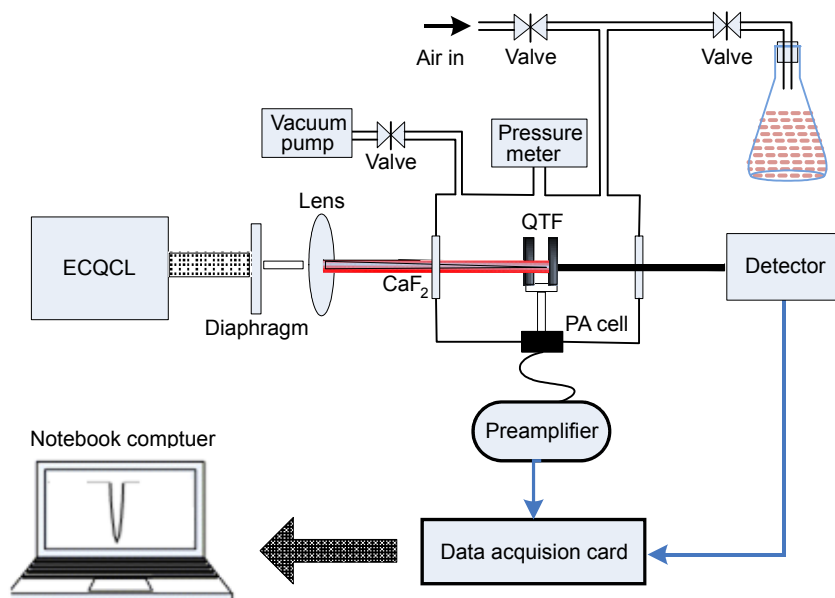

Fig. 2. Diagram of experimental setup.

1.25 MHz sampling rate), as well as a gas sampling line, which mainly includes some needle valves, an air pump and a digital pressure gauge (Testo 552, Germany). The stainless steel PA cell consists of two CaF₂ windows and a quartz tuning fork (QTF) as an acoustic signal detector, which was installed in the center of PA cell. A home-made low noise transimpedance preamplifier circuit with a feedback resistor of 10 M Ω was applied to magnify and transform the piezoelectric current generated by the QTF into a voltage signal. The divergent ECQCL laser beam is firstly shaped and collimated, and then passes through the gap of the QTF. Finally, the transmitted laser beam was detected by a standard MCT used for recorded direct DAS signal synchronously. Both PA and DAS signals were digitized by a data acquisition system based on LabVIEW software and a laptop computer for data storage and signal processing.

To investigate the characteristics of QTF as an acoustic detector, a near-infrared diode laser model operated at a fixed wave number of 6578.576 cm⁻¹ corresponding to the line R9e of C₂H₂ was first used as the excitation light source to generate PA signal. We performed this experiment by applying a sinusoidal modulation to the diode laser current, while scanning the modulation frequency around the QTF resonance frequency (*i.e.* 32.768 kHz) to observe its resonant effect. The recorded resonant profile was finally fitted by using a Lorentzian function. As shown in Fig. 3, the fitted parameters were also provided in the inset, the selected QTF detector had a resonant frequency of 32.744 kHz in ambient pressure (*i.e.* 1 atm) and a quality factor Q of 7351.4. The Q value was calculated as the ratio of the resonance frequency to the frequency bandwidth, which represents the signal enhancement factor.

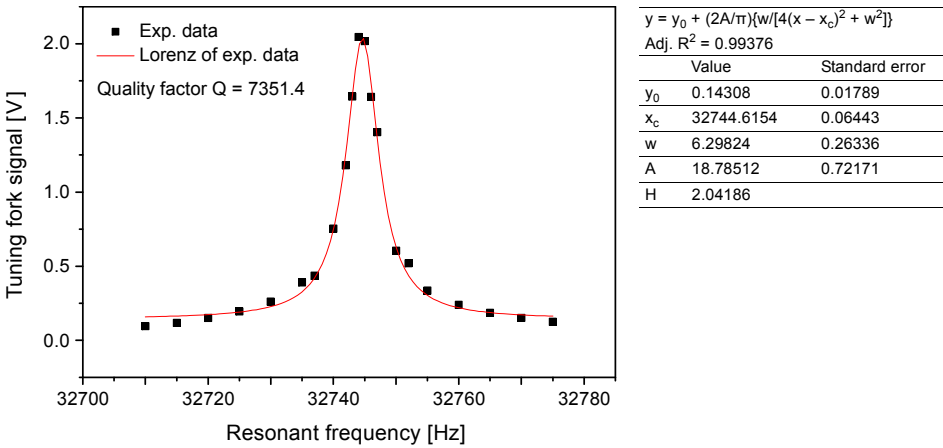

Fig. 3. The measured QTF resonant profile at ambient air, the acquired curve yielded $Q = 7351.4$.

The ECQCL can be programmed to emit pulses from 20 to 450 ns with a pulse repetition rate up to 3 MHz. For a more detailed description of the laser source we refer the reader to [15]. In case of QEPAS, the PA signal amplitude shows significant dependence on laser power. Therefore, the ECQCL characteristic was primarily investigated. Experimentally, the ECQCL laser pulse repetition rate was always fixed to match the QTF resonant frequency. The laser output power was measured using a power meter (Nova II, Ophir Photonics) after the laser exit and PA cell, respectively. Figure 4 presents the relationship between the maximal laser output power at 1300 cm^{-1} and laser pulse duration, and a good linear dependence of laser power on the laser pulse duration was found in the range from 150 to 450 ns. Finally, the maximal laser power in the PA cell is estimated to be less than 2 mW.

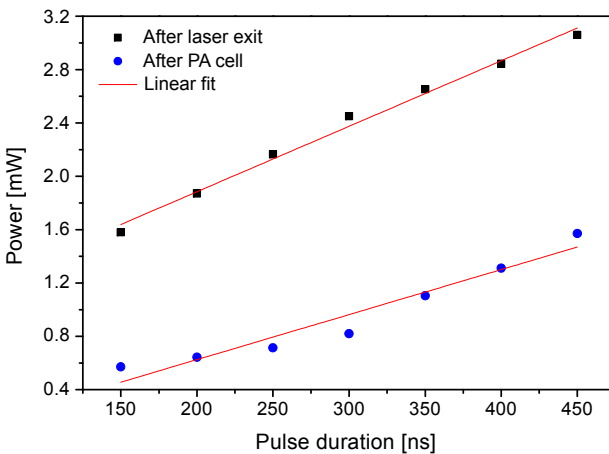

Fig. 4. The relationship between laser output power and pulse duration.

3. Results and discussion

In this work, ethanol vapor gas was used for evaluating the experimental system. The VOC gas sample was prepared as follows: ethanol liquid with a stated purity of 99.7% was pipetted in a flask connected with the PA cell. The whole experiments were made at one atmospheric pressure and room temperature. The PA cell was firstly filled with ambient air and measured for background spectrum. For ethanol spectroscopy measurements, the PA cell was always evacuated for tens of minutes, and then it was filled with ethanol vapor with different pressure and mixed with ambient air to a total pressure of 1 atm for PA signal measurements. The ECQCL was set with a repetition rate of 32.744 kHz to match with the QTF resonant frequency, and pulse duration of 450 ns to provide the maximal output power. Generally, it took us approximately 160 s to acquire a whole scanning between 1160 and 1320 cm^{-1} for wavelength-sweeping mode. In Figure 5 as an example, we present the experimentally measured ethanol PA spectra (Fig. 5a) and reference spectrum (Fig. 5b) taken from PNNL database. As

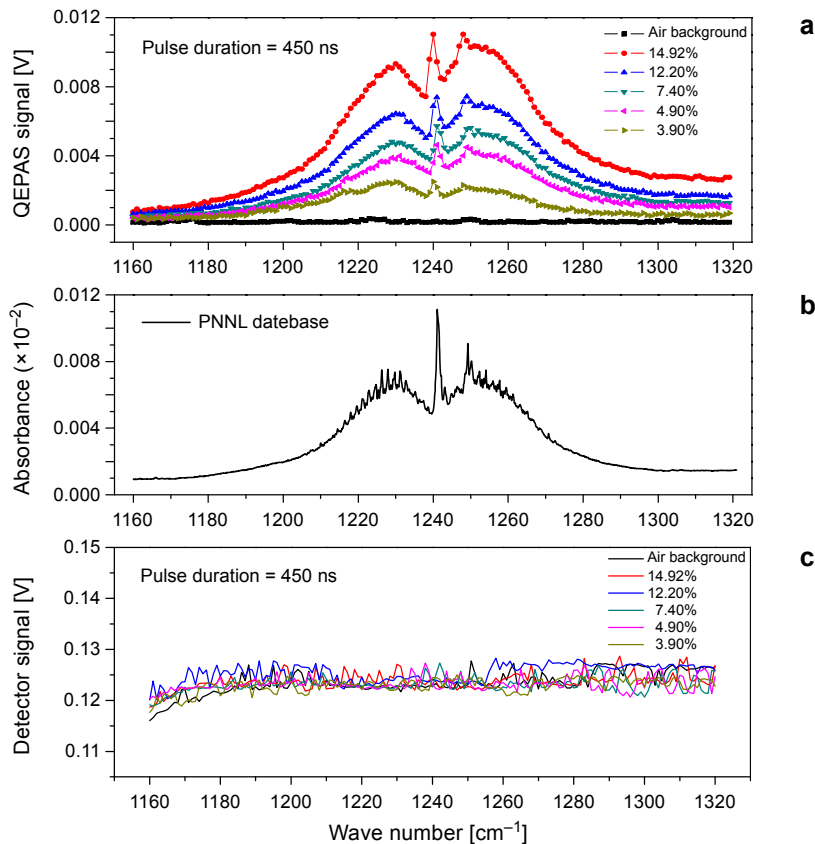

Fig. 5. Experimentally measured ethanol PA spectra under different concentration (a), the corresponding data extracted from PNNL database (b) and the corresponding DA signal (c).

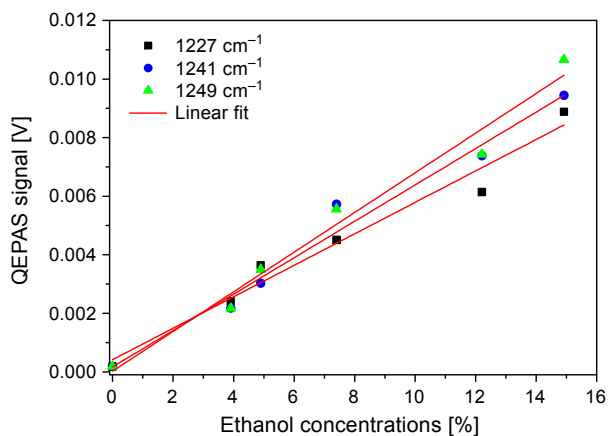

Fig. 6. The PA signals at 1227, 1241 and 1249 cm^{-1} as a function of ethanol concentrations, and the straight lines are the best linear fit of experimental data.

can be seen, the measured ethanol PA spectra compare reasonably well with the standard reference spectrum, except the finger-like fine structure. The wave number resolution of PNNL data is 0.06 cm^{-1} , whereas the experimentally observed wave number resolution is only 1 cm^{-1} , mainly limited by the pulse ECQCL line width and the system sampling rate. For comparison, the corresponding DAS spectra (Fig. 5c) with very poor SNR were also presented. The results prove that QEPAS technique is more sensitive than the traditional DAS method. A comparison of detection limit with other QEPAS sensor systems is not straightforward, in view of rather different experimental configurations and sometimes lack of specific information. Anyway, a minimum detection limit of $\sim 700 \text{ ppmv}$ (at 1249 cm^{-1}) was estimated for the QEPAS detection method, and the sensitivity achieved here is acceptable, in view of so lower laser power available in this work (less than 2 mW). Moreover, the PA signal at 1227, 1241 and 1249 cm^{-1} were plotted as a function of ethanol concentrations in Fig. 6. From this figure, a good linearity can be seen. Linear regression leads to a regression coefficient R^2 of 0.96, 0.97 and 0.97 were obtained, respectively. The slightly poor linearity might be due to the strong adsorption effect of ethanol. Note that each signal was recorded with a single scan acquisition without any signal averaging and wavelength calibration.

In order to further test the system performance, the dependence of PA signal on laser power was also observed. As previously reported [15], the ECQCL output power shows a strong dependence on a pulse repetition rate and pulse width. In this study, the pulse repetition rate must be fixed to the QTF resonant frequency. Therefore, only pulse width can be tuned for observing this effect. Figure 7a demonstrated the experimentally recorded PA spectra at a constant ethanol concentration as a function of the ECQCL pulse width, as well as the plot of PA signal amplitude at three different positions vs. the ECQCL pulse width (Fig. 7b). As expected, a good linear dependence of PA signal

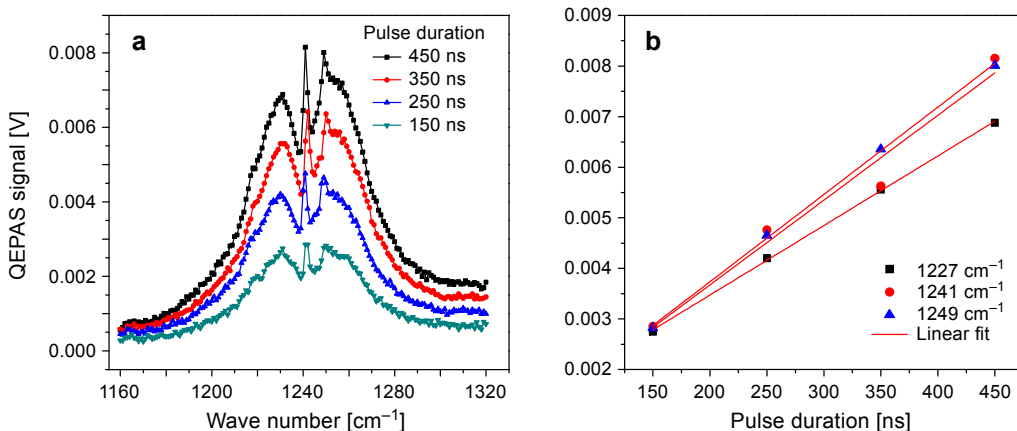

Fig. 7. Experimentally measured ethanol PA spectra under different pulse duration (a) and the relationship between PA signal amplitude and pulse duration (b).

at 1227, 1241 and 1249 cm⁻¹ on pulse width was obtained, with a regression coefficient R^2 of 0.99, 0.95 and 0.99, respectively. The results indicate that the PA signal is proportional to the incident laser power and the concentration of the absorbing molecule. Thus, QEPAS detection of trace gases derives sensitivity benefit from the use of as much laser power as is available.

4. Conclusions

In this paper, a QEPAS gas detection system based on an ECQCL was developed for measuring volatile organic compounds (VOC). The PA and DAS spectra of ethanol between 1160 and 1320 cm⁻¹ were simultaneously measured. The results show that PA detection scheme is more sensitive than the DAS method. The good linear relationship between laser output power and pulse duration was found. In case of PA or QEPAS technique, the PA signal amplitude is proportional to the incident light power, the PA signal is therefore proportional to the pulse duration and the sample pressure of the absorbing molecule, which was experimentally verified. Note that the effective laser power used in PA cell is estimated to be less than 2 mW, and all the experimental spectra were recorded with a single scan acquisition without the use of the lock-in amplifier and without any multi-signal averaging. Future work will focus on the optimization of the QTF selection and detection schemes, for example, the selection of QTFs with high resonant frequency to make full use of the ECQCL power, and using an acoustic micro-resonator to enhance PA signal [16], as well as digital signal processing methods [17, 18], *etc.* Based upon these detection methods, the system sensitivity is expected to be improved dramatically. The wide wavelength tunability of ECQCL will allow us to access the fundamental vibrational bands of many chemical

agents, which are well-suited for trace explosive, chemical warfare agent, and toxic industrial chemical detection and spectroscopic study [19, 20].

Acknowledgements – The authors gratefully acknowledge the financial support from the National Program on Key Research and Development Project (2016YFC0302202); the National Natural Science Foundation of China (61705002, 61675005); the Natural Science Fund of Anhui Province (1508085MF118); the Key Science and Technology Development Program of Anhui Province (1501041136), the Technology Foundation for Selected Overseas Chinese Scholar (J05015143), and Anhui University Personnel Recruiting Project of Academic and Technical Leaders (J01006031).

References

- [1] FAIST J., CAPASSO F., SIVCO D.L., SIRTORI C., HUTCHINSON A.L., CHO A.Y., *Quantum cascade laser*, [Science](#) **264**(5158), 1994, pp. 553–555.
- [2] GMACHL C., CAPASSO F., SIVCO D.L., CHO A.Y., *Recent progress in quantum cascade lasers and applications*, *Reports on Progress in Physics* **64**(11), 2001, pp. 1533–1601.
- [3] LI J.S., CHEN W., FISCHER H., *Quantum cascade laser spectrometry techniques: a new trend in atmospheric chemistry*, [Applied Spectroscopy Reviews](#) **48**(7), 2013, pp. 523–559.
- [4] JINGSONG LI, HAO DENG, JUAN SUN, BENLI YU, FISCHER H., *Simultaneous atmospheric CO, N₂O and H₂O detection using a single quantum cascade laser sensor based on dual-spectroscopy techniques*, [Sensors and Actuators B: Chemical](#) **231**, 2016, pp. 723–732.
- [5] HUGI A., TERAZZI R., BONETTI Y., WITTMANN A., FISCHER M., BECK M., FAIST J., GINI E., *External cavity quantum cascade laser tunable from 7.6 to 11.4 μm* , [Applied Physics Letters](#) **95**(6), 2009, article ID 061103.
- [6] BANDYOPADHYAY N., CHEN M., SENGUPTA S., SLIVKEN S., RAZEGHI M., *Ultra-broadband quantum cascade laser, tunable over 760 cm^{-1} , with balanced gain*, [Optics Express](#) **23**(16), 2015, pp. 21159–21164.
- [7] BELL A.G., *On the production and reproduction of sound by light*, [American Journal of Science](#) **20**(118), 1880, pp. 305–324.
- [8] FRIEDT J.-M., CARRY E., *Introduction to the quartz tuning fork*, [American Journal of Physics](#) **75**(5), 2007, pp. 415–422.
- [9] KOSTEREV A.A., BAKHIRKIN YU.A., CURL R.F., TITTEL F.K., *Quartz enhanced photoacoustic spectroscopy*, [Optics Letters](#) **27**(21), 2002, pp. 1902–1904.
- [10] SHENG ZHOU, YANLING HAN, BINCHENG LI, *Simultaneous detection of ethanol, ether and acetone by mid-infrared cavity ring-down spectroscopy at 3.8 μm* , [Applied Physics B](#) **122**, 2016, article ID 187.
- [11] LEWICKI R., WYSOCKI G., KOSTEREV A.A., TITTEL F.K., *QEPAS based detection of broadband absorbing molecules using a widely tunable, cw quantum cascade laser at 8.4 μm* , [Optics Express](#) **15**(12), 2007, pp. 7357–7366.
- [12] KOSTEREV A.A., BUERKI P.R., DONG L., REED M., DAY T., TITTEL F.K., *QEPAS detector for rapid spectral measurements*, [Applied Physics B](#) **100**(1), 2010, pp. 173–180.
- [13] SHARPE S.W., JOHNSON T.J., SAMS R.L., CHU P.M., RHODERICK G.C., JOHNSON P.A., *Gas-phase databases for quantitative infrared spectroscopy*, *Applied Spectroscopy* **58**(12), 2004, pp. 1452–1461.
- [14] NADEZHINSKII A., BEREZIN A., BUGOSLAVSKY YU., ERSHOV O., KUTNYAK V., *Application of near-IR diode lasers for measurement of ethanol vapor*, [Spectrochimica Acta Part A: Molecular and Biomolecular Spectroscopy](#) **55**(10), 1999, pp. 2049–2055.
- [15] JUAN SUN, HAO DENG, NINGWU LIU, HONGLIANG WANG, BENLI YU, JINGSONG LI, *Mid-infrared gas absorption sensor based on a broadband external cavity quantum cascade laser*, [Review of Scientific Instruments](#) **87**(12), 2016, article ID 123101.

- [16] AOUST G., LEVY R., RAYBAUT M., GODARD A., MELKONIAN J.-M., LEFEBVRE M., *Theoretical analysis of a resonant quartz-enhanced photoacoustic spectroscopy sensor*, [Applied Physics B 123](#), 2017, [article ID 63](#).
- [17] JINGSONG LI, HAO DENG, PENGFEI LI, BENLI YU, *Real time infrared gas detection based on an adaptive Savitzky–Golay algorithm*, [Applied Physics B 120\(2\)](#), 2015, pp. 207–216.
- [18] HAO DENG, JUAN SUN, PENGFEI LI, YU LIU, BENLI YU, JINGSONG LI, *Sensitive detection of acetylene by second derivative spectra with tunable diode laser absorption spectroscopy*, [Optica Applicata 46\(3\)](#), 2016, pp. 353–363.
- [19] IVASCU I.R., MATEI C.E., PATACHIA M., BRATU A.M., DUMITRAS D.C., *CO₂ laser photoacoustic measurements of ethanol absorption coefficients within infrared region of 9.2–10.8 μm*, [Spectrochimica Acta Part A: Molecular and Biomolecular Spectroscopy 163](#), 2016, pp.115–119.
- [20] LI J.S., YU B., FISCHER H., CHEN W., YALIN A.P., *Contributed review: quantum cascade laser based photoacoustic detection of explosives*, [Review of Scientific Instruments 86\(3\)](#), 2015, [article ID 031501](#).

*Received January 7, 2018
in revised form March 4, 2018*